

# Background: Operating Systems

Brad Karp  
UCL Computer Science



CS GZ03 / M030  
30<sup>th</sup> September 2013

# Outline

- Goals of an operating system
- Sketch of UNIX
  - User processes, kernel
  - Process-kernel communication
  - Waiting for I/O
- Simple web server design

# Why Discuss OS Now?

- Real distributed systems run on an OS
- OS details affect design, robustness, performance
  - Sometimes because of OS idiosyncrasies
  - More often because OS already solves some hard problems
- **Ask questions if something isn't clear!**
- Further reading:
  - General overview:  
Tanenbaum, *Modern Operating Systems*, 3<sup>rd</sup> Edition
  - Details of a modern UNIX:  
McKusick et al., *The Design and Implementation of the 4.4 BSD Operating System*

# Goals of OS Designers

- Share hardware resources
  - e.g., one CPU, many applications running
- Protection (app-to-app, app-to-OS)
  - Bug in one app shouldn't crash whole box or bring down other app
- Communication (app-to-app, app-to-OS)
- Hardware independence
  - Don't want to rewrite apps for each new CPU, each new I/O device
- How? Using abstractions and well-defined interfaces

# UNIX Abstractions

- Process
  - Address space
  - Thread of control
  - User ID
- Filesystem
- File Descriptor
  - File on disk
  - Pipe between processes
  - Network connection
  - Hardware device

# OS Virtualizes Hardware

- Kernel implements abstractions, executes with privilege to directly touch hardware
- OS multiplexes CPU, memory, disk, network among multiple processes (apps)
- Apps can **share resources**
- Apps can **control resources**
- Apps see **simple interface**

# OS Abstraction Design

- OS abstractions interact
  - If can start program, must be able to read executable file
- Processes see **system call** interface to kernel abstractions
  - Looks like function call, but special
  - e.g., `fork()`, `exec()`
  - e.g., `open()`, `read()`, `creat()`

# Typical UNIX System

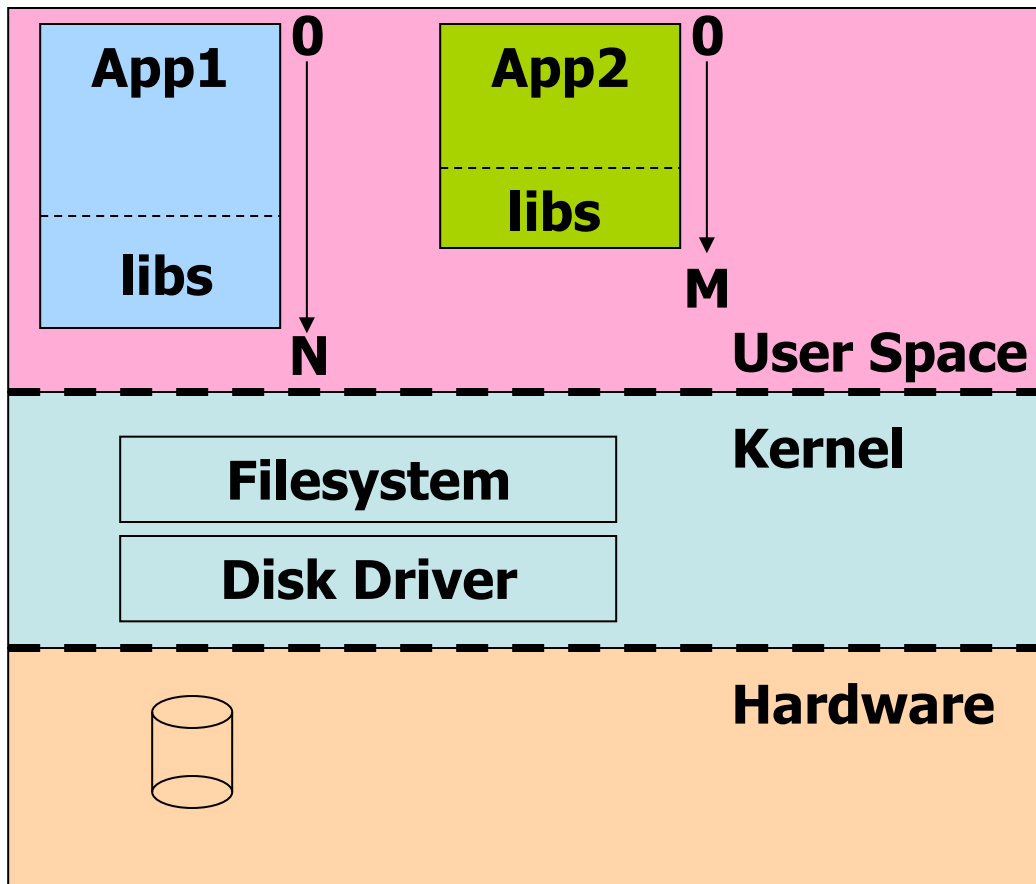

- App1 and App2 in separate address spaces; protected from one another
- Hardware runs kernel with elevated privilege



# Typical UNIX System

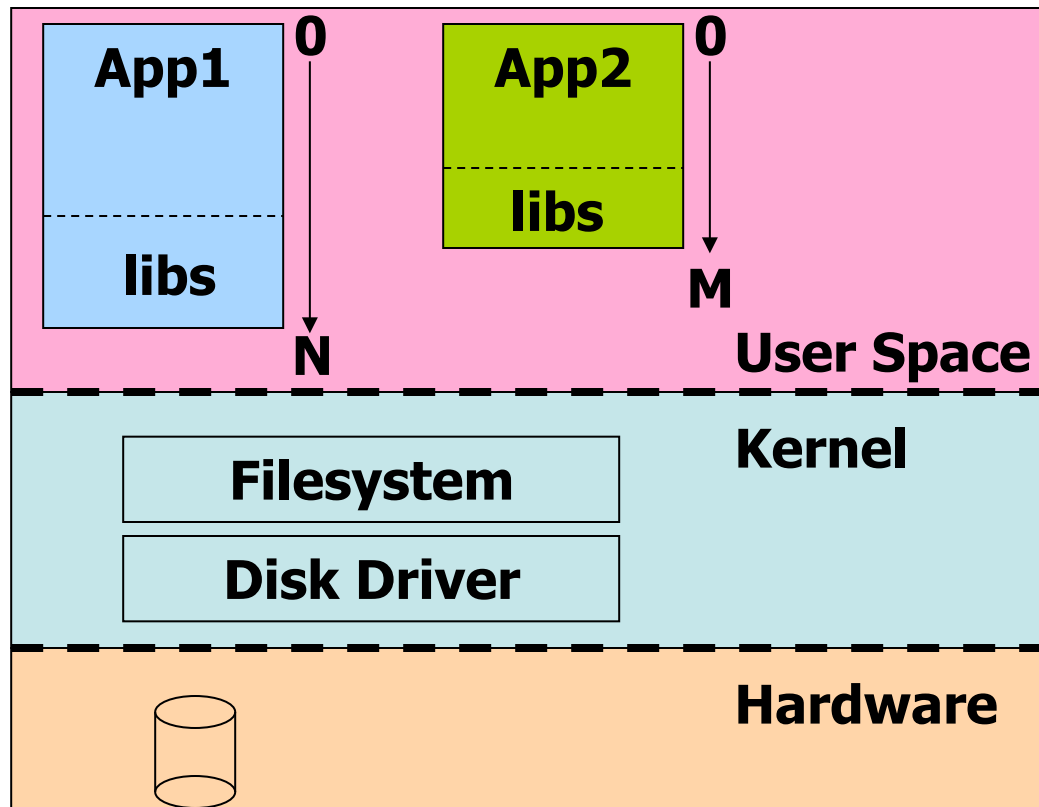

- App1 and App2 in separate address spaces; protected from one another
- Hardware runs kernel with elevated privilege

**How do processes and kernel communicate?  
How do processes and kernel wait for events  
(e.g., disk and network I/O)?**

# System Calls: Process-Kernel Communication

- Application closes a file:

```
close(3);
```

- C library:

```
close(x) {  
    R0 <- 73  
    R1 <- x  
    TRAP  
    RET  
}
```

# System Calls: Traps

- TRAP instruction:
  - XP <- PC
  - switch to kernel address space
  - set privileged flag
  - PC <- address of kernel trap handler
- Kernel trap handler:
  - save regs to this process' "process control block" (PCB)
  - set SP to kernel stack
  - call sys\_close(), ordinary C function
  - ...now executing in "kernel half" of process...
  - restore registers from PCB
  - TRAPRET

# System Calls: TRAPRET

- TRAPRET instruction:
  - PC  $\leftarrow$  XP
  - clear privileged flag
  - switch to process address space
  - continue execution

# System Call Properties

- Protected transfer
  - Process granted kernel privilege level by hardware
  - But jump **must be to known kernel entry point**
- Process suspended until system call finishes
- **What if system call must wait (e.g., read() from disk)?**

# Blocking I/O

- On a busy server, system calls often must wait for I/O; e.g.,
- `sys_open(path)`
  - for each pathname component
  - start read of directory from disk
  - sleep waiting for disk read
  - process directory contents
- `sleep()`
  - save kernel regs to PCB1 (including SP)
  - find runnable PCB2
  - restore PCB2 kernel registers (SP, &c.)
  - return

# Blocking I/O

- On a busy server, system calls often must wait for I/O; e.g.,
- `sys_open(path)`  
for each pathname component

**Each user process has kernel stack  
contains state of pending system call  
System call "blocks" while awaiting I/O**

- `sleep()`
  - save kernel regs to PCB1 (including SP)
  - find runnable PCB2
  - restore PCB2 kernel registers (SP, &c.)
  - return

# Disk I/O Completion

- How does process continue after disk I/O completes?
- Disk controller generates **interrupt**
- Device interrupt routine in kernel finds process blocked on that I/O
- Marks process as **runnable**
- Returns from interrupt
- Process scheduler will **reschedule waiting process**



# How Do Servers Use Syscalls?

- Consider server\_1() web server (in handout)

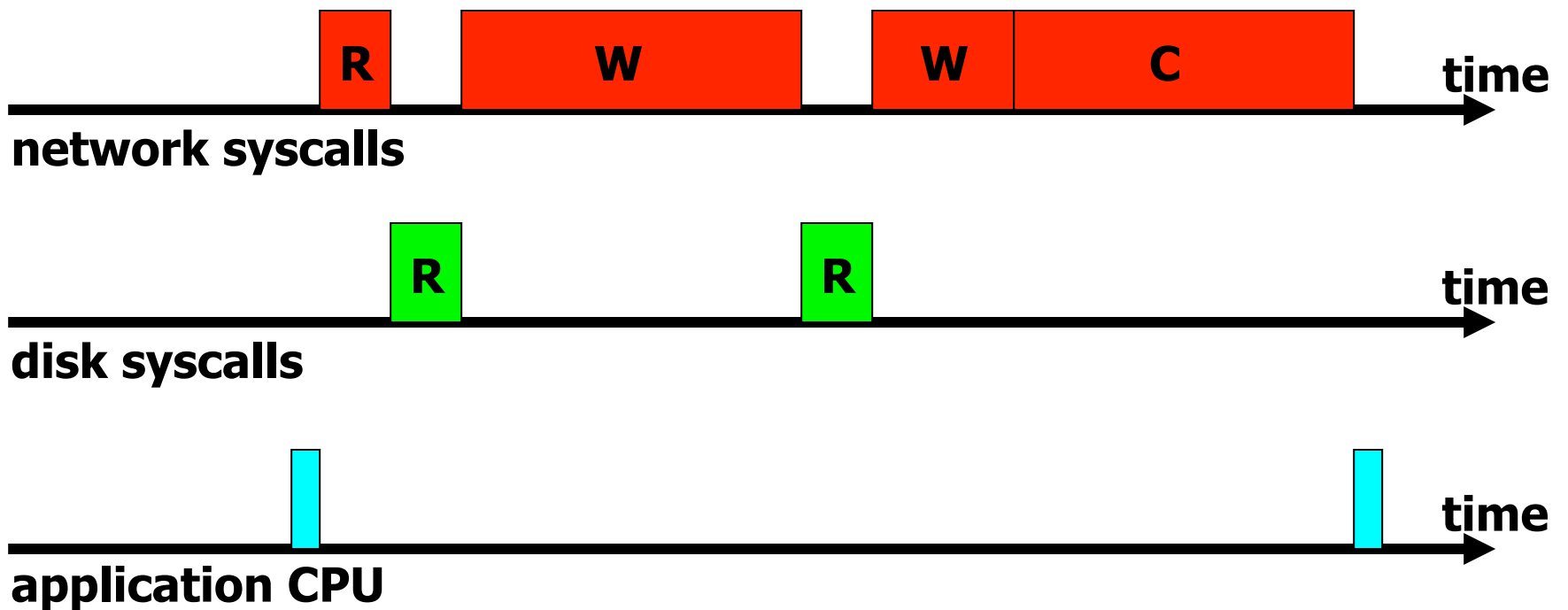

# How Do Servers Use Syscalls?

Server waits for each resource in turn

Each resource largely idle

What if there are many clients?

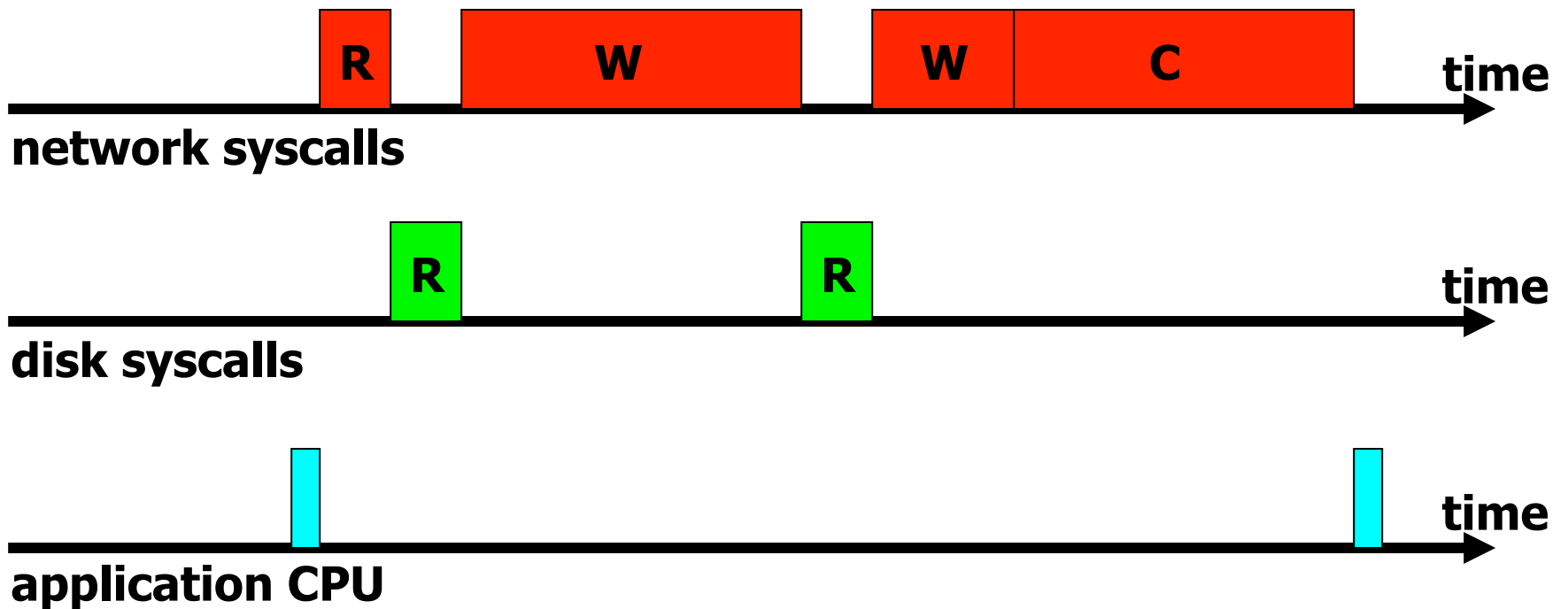

# Performance and Concurrency

- Under heavy load, server\_1():
  - Leaves resources idle
  - ...and has a lot of work to do!
- Why?
  - Software poorly structured!
  - What would a better structure look like?

# Solution: I/O Concurrency

- Can we overlap I/O with other useful work? Yes:
  - Web server: if files in disk cache, I/O wait spent mostly **blocked on write to network**
  - Networked file system client: could **compile first part of file while fetching second part**
- Performance benefits potentially huge
  - Say one client causes disk I/O, **10 ms**
  - **If other clients' requests in cache, could serve 100 other clients during that time!**

# Solution: I/O Concurrency

- Can we overlap I/O with other useful work? Yes:
  - Web server: if files in disk cache, I/O wait spent mostly **blocked on write to network**

**Next: how to achieve I/O concurrency!**

- Performance benefits potentially huge
  - Say one client causes disk I/O, **10 ms**
  - **If other clients' requests in cache, could serve 100 other clients during that time!**