

Bayou: Replication with Weak Inter-Node Connectivity

Brad Karp

UCL Computer Science



CS GZ03 / M030

4th November, 2009

Context: Availability vs. Consistency

- NFS, Ivy, 2PC all had single points of failure; **not available under failures**
- Paxos allows view-change to elect primary, thus state machine replication
 - **Strong consistency model: all operations in same order at all replicas, always appearance of single system-wide order for all operations**
 - **Strong reachability requirement: majority of nodes must be reachable by leader**
- **If reachability weaker, can we provide any consistency when we replicate?**

Bayou: Calendar Application Case Study

- Today's lecture:
 - Bayou's office calendar application as case study in ordering and conflicts in a distributed system with poor connectivity
- Each calendar entry: room, time, and set of participants
- Want everyone to see same set of entries (eventually)
 - else, users may double-book room, avoid using unoccupied room, &c.

Traditional Calendar Application: One Central Server

- Ordering of users' requests: **only one copy, server picks order**
- Conflict resolution: **server checks for conflicts** (i.e., "is this room already booked during this period?") **before accepting updates**
 - Returns error to user if conflict; user decides what to do

What's Wrong with Central Server?

- Want my calendar **on my PDA**
 - i.e., **each user** wants database replicated on his PDA or laptop
 - No master copy
- PDA has only **intermittent connectivity**
 - **GPRS/EDGE/3G expensive, WiFi not everywhere; nothing on Tube**
 - Bluetooth useful for **direct contact with other calendar users' PDAs**, but **very short range**

Simple Proposal: Swap Complete DBs

- Suppose two users in Bluetooth range
- Each sends entire calendar DB to other, as with Palm sync
- Possibly **lots of network bandwidth**
- What if **conflict**, i.e., two concurrent meetings?
 - Palm sync just keeps both meetings!
 - Want to do better: **automatic conflict resolution**

Automatic Conflict Resolution

- Can't just view DB items as bits—**too little information to resolve conflicts!**
 - “Both files have changed” can falsely conclude entire DBs conflict
 - “Distinct record in each DB changed” can falsely conclude no conflict
- Want to build **intelligent DB app** that **knows how to resolve conflicts**
 - More like users' updates: **read DB, think, change request to eliminate conflict**
 - Must ensure all nodes **resolve conflicts in same way** to keep replicas consistent

Insight: Ordering of Updates

- Maintain ordered list of updates at each node
- Make sure every node holds same updates
- Make sure every node applies updates in same order
- Make sure updates are deterministic function of DB contents
- If we obey above, **“sync” really just a simple merge of two ordered lists!**

What's in a Write?

- Each node's ordered list of writes: write log
- Suppose calendar update takes form:
 - "10 AM meeting, Room 6.12, Mark and Brad"
 - **Sufficient for our goal?**
- Better: "1-hour meeting, Room 6.12, Mark and Brad, at 9, else 10, else 11"
 - Also include unique ID: <local-time-stamp, originating-node-ID>

What's in a Write?

Instructions for write more than data to write

Write log really an "instruction" for calendar program

Want all nodes to execute **same instructions in same order**, eventually

- Better: "1-hour meeting, Room 6.12, Mark and Brad, at 9, else 10, else 11"
 - Also include unique ID: <local-time-stamp, originating-node-ID>

Write Log Example

- $\langle 701, A \rangle$: Node A asks for meeting M1 to occur at 10 AM, else 11 AM
- $\langle 770, B \rangle$: Node B asks for meeting M2 to occur at 10 AM, else 11 AM
- Let's agree to sort by write ID (e.g., $\langle 701, A \rangle$)
- As "writes" spread from node to node, nodes may initially **apply updates in different orders**

Write Log Example (2)

- Each newly seen write merged into log
- Log replayed
 - May cause calendar displayed to user to change!
 - i.e., all entries really “tentative,” nothing stable
- After everyone has seen all writes, everyone will agree (contain same state)

Global Time Synchronization Impossible

- Does this mean that globally ordering writes by local timestamps impossible?
- No—timestamps just allow **agreement on order**
 - Nodes may have wrong clocks
 - OK, so long as users **don't expect writes to reach calendar in real-time order made**

Timestamps for Write Ordering: Limitations

- Ordering by write ID arbitrarily constrains order
 - Never know if some write from past hasn't yet reached your node
 - So all entries in log must be **tentative forever**
 - And you must **store entire log forever**
- Problem: how can we allow committing a tentative entry?
 - So we can **have meetings and trim logs**

Criteria for Committing Writes

- For log entry X to be committed, everyone must agree on:
 - Total order of all previous committed entries
 - Fact that X is next in total order
 - Fact that all uncommitted entries are “after” X

How Bayou Agrees on Total Order of Committed Writes

- One node designated “primary replica”
- Primary marks each write it receives with permanent CSN (commit sequence number)
 - That write is committed
 - Complete timestamp is $\langle \text{CSN}, \text{local-TS}, \text{node-id} \rangle$
- Nodes exchange CSNs
- CSNs define total order for committed writes
 - All nodes eventually agree on total order
 - Uncommitted writes come after all committed writes

Showing Users that Writes Have Committed

- Still not safe to show users that an appointment request has committed
- Entire log up to newly committed entry must be committed
 - else there might be earlier committed write a node doesn't know about!
 - ...and upon learning about it, would have to re-run conflict resolution
- Result: committed write not stable unless node has seen all prior committed writes

Showing Users that Writes Have Committed

Bayou propagates writes between nodes to enforce this invariant

i.e., **Bayou propagates writes in order**

must be committed

- else there might be earlier committed write a node doesn't know about!
- ...and upon learning about it, **would have to re-run conflict resolution**
- Result: **committed write not stable unless node has seen all prior committed writes**

Committed vs. Tentative Writes

- Can now show user if a write has committed
 - When node has seen every CSN up to that point, as guaranteed by propagation protocol
- Slow or disconnected node cannot prevent commits!
 - Primary replica allocates CSNs; global order of writes may not reflect real-time write times
- What about tentative writes, though—how do they behave, as seen by users?

Tentative Writes

- Two nodes may disagree on meaning of tentative (uncommitted) writes
 - **Even if those two nodes have synced with each other!**
 - Only CSNs from primary replica can resolve these disagreements permanently

Example: Disagreement on Tentative Writes

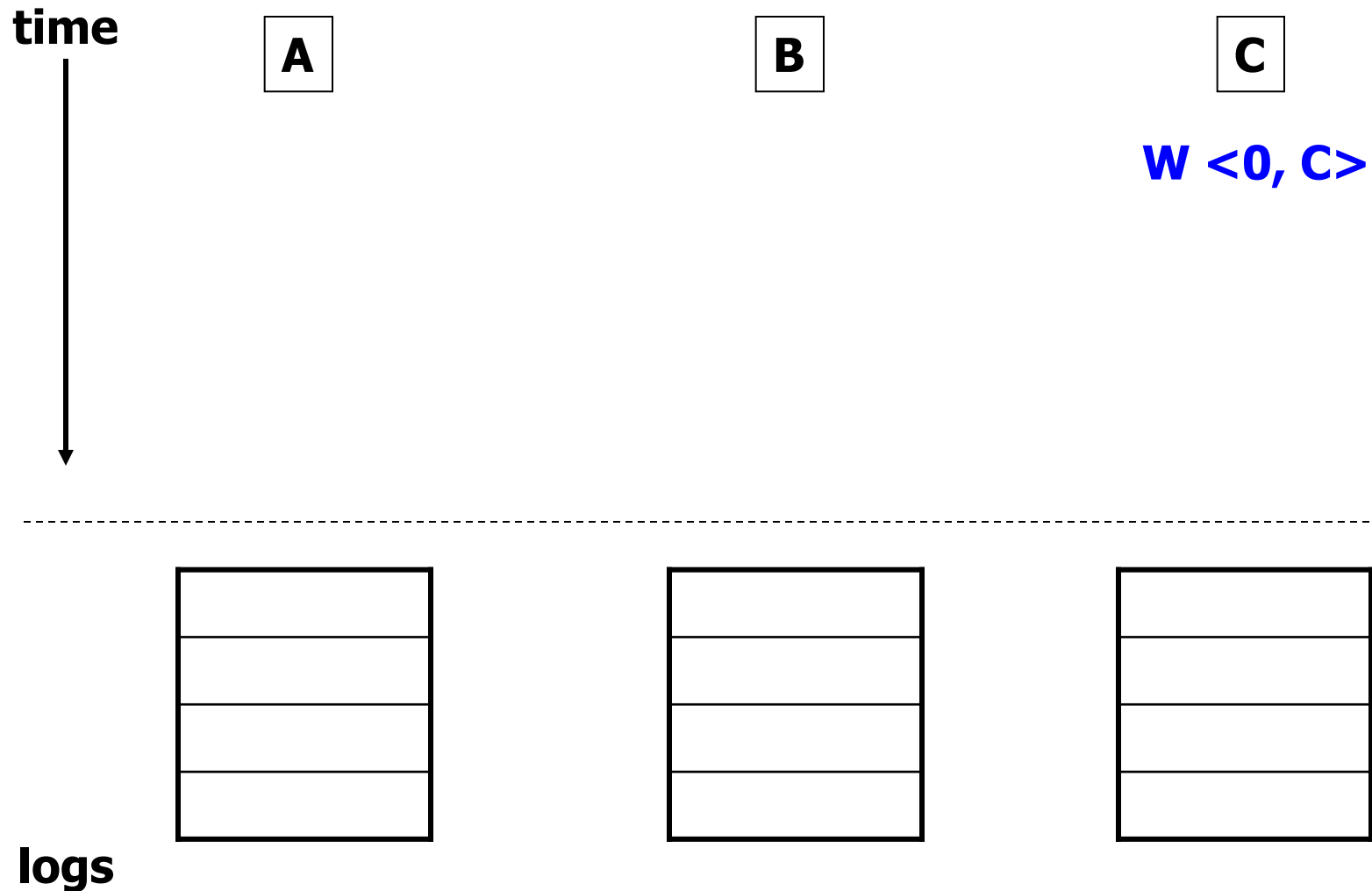

Example: Disagreement on Tentative Writes

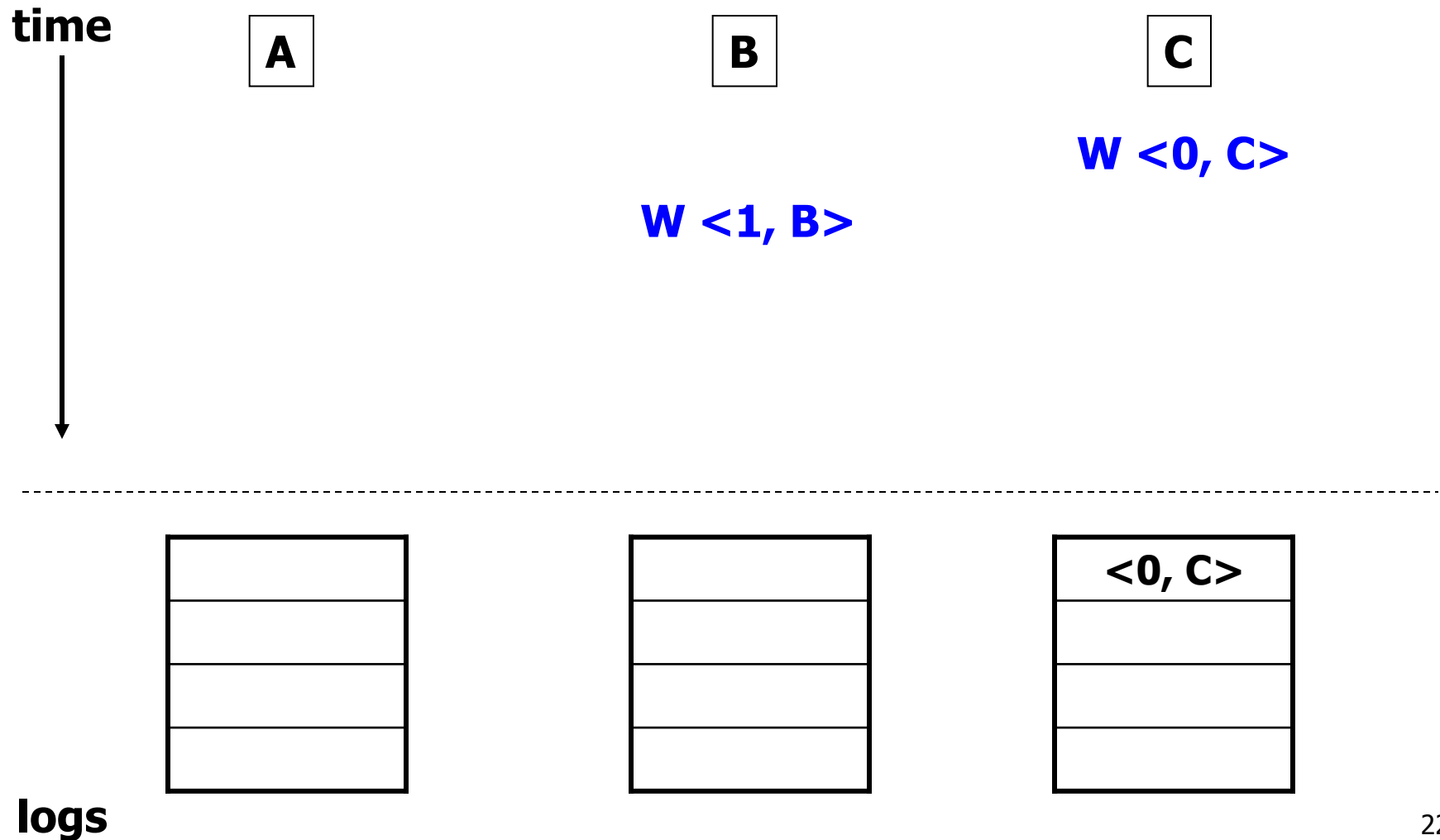

Example: Disagreement on Tentative Writes

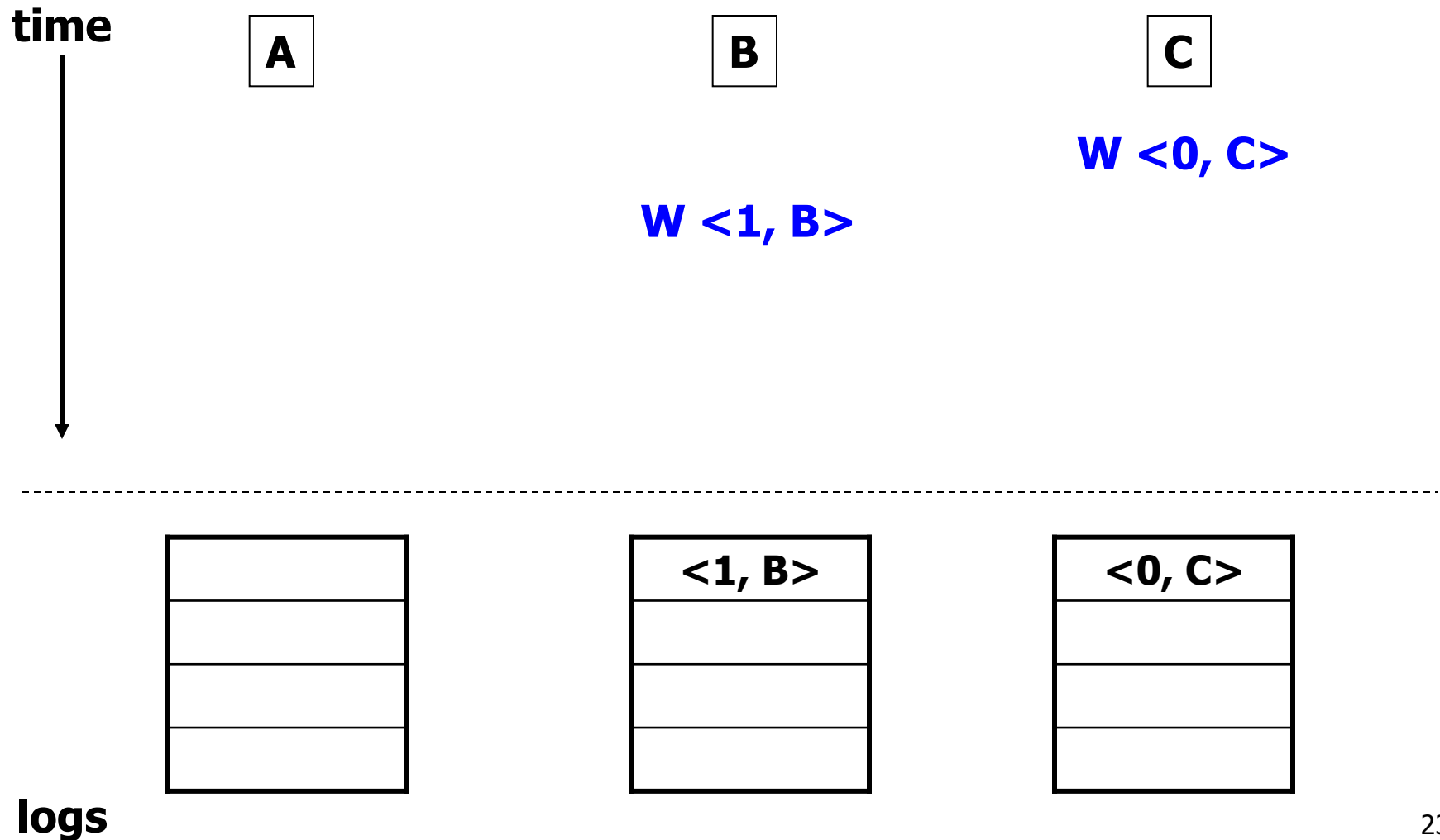

Example: Disagreement on Tentative Writes

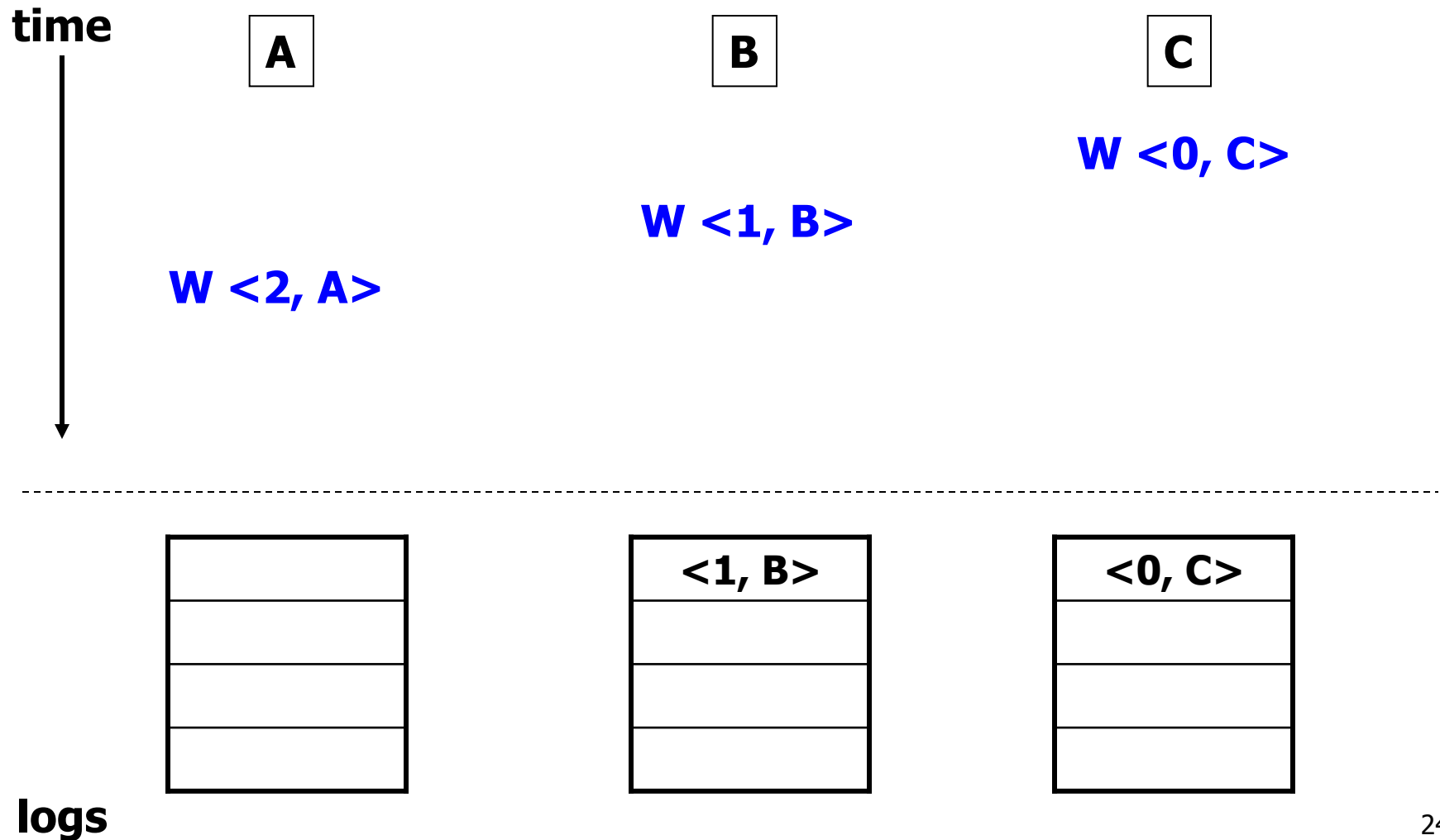

Example: Disagreement on Tentative Writes

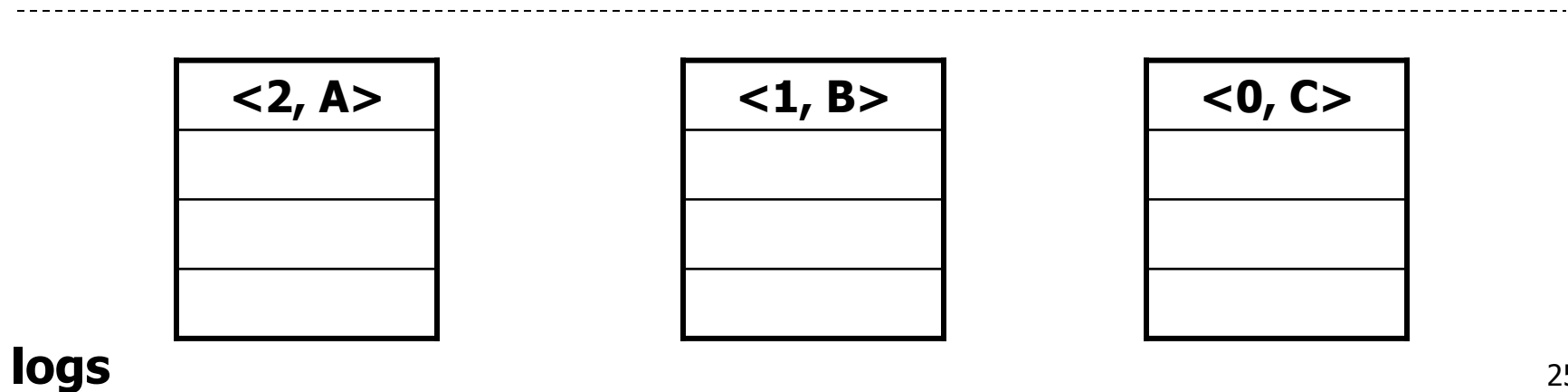
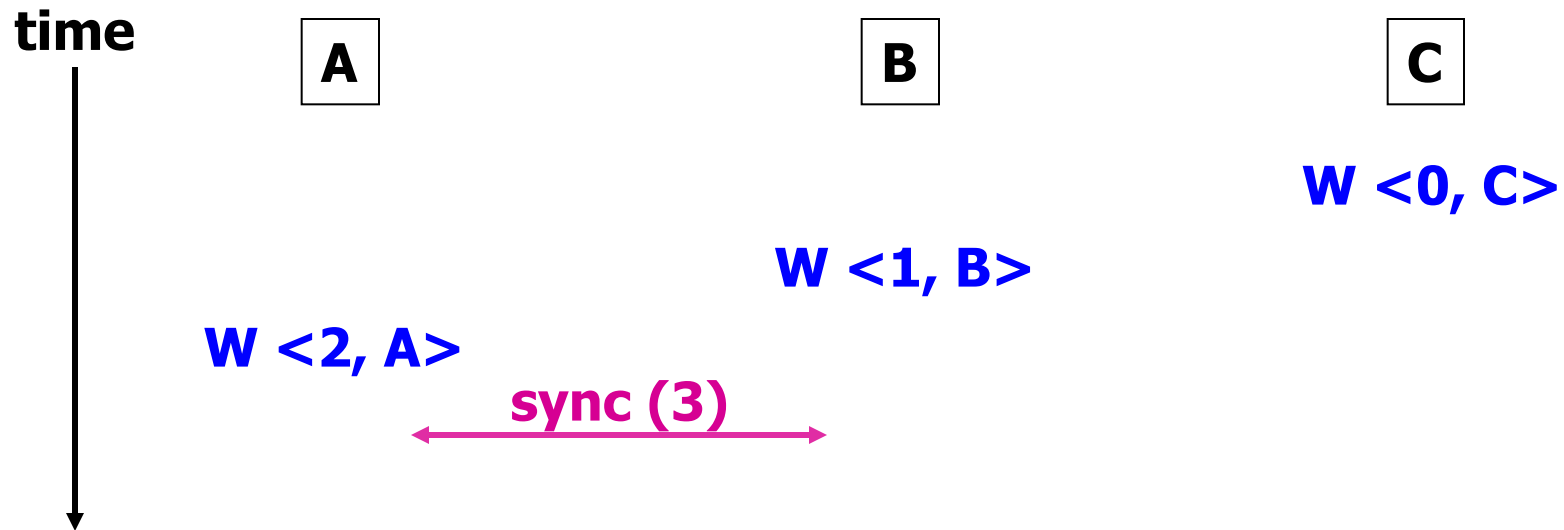

Example: Disagreement on Tentative Writes

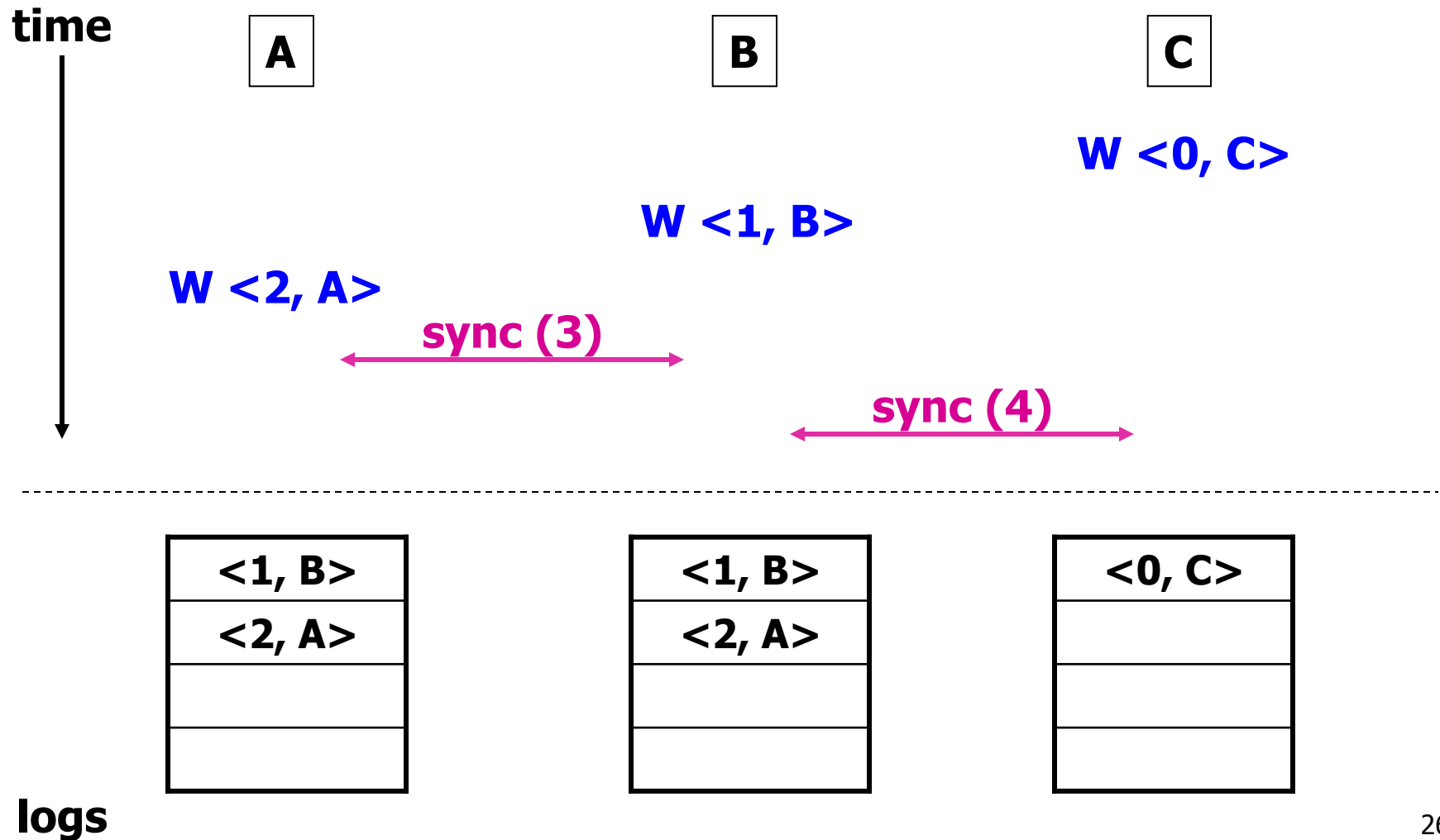

Example: Disagreement on Tentative Writes

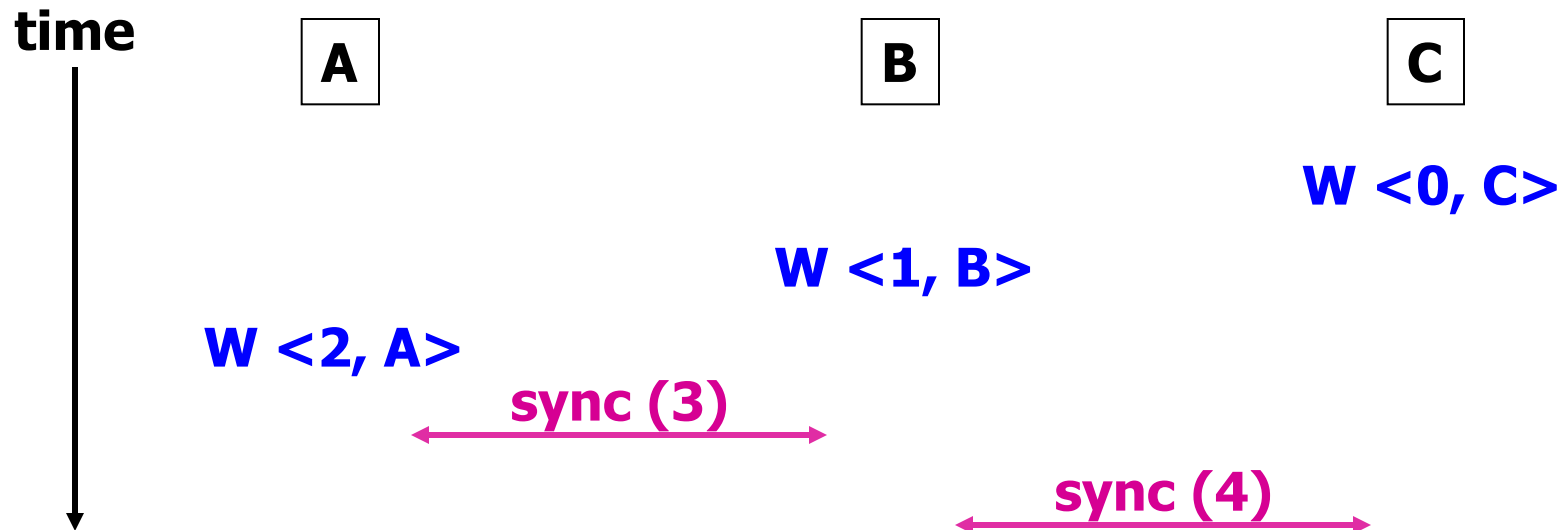

<1, B>
<2, A>

<0, C>
<1, B>
<2, A>

<0, C>
<1, B>
<2, A>

logs

Example: Disagreement on Tentative Writes

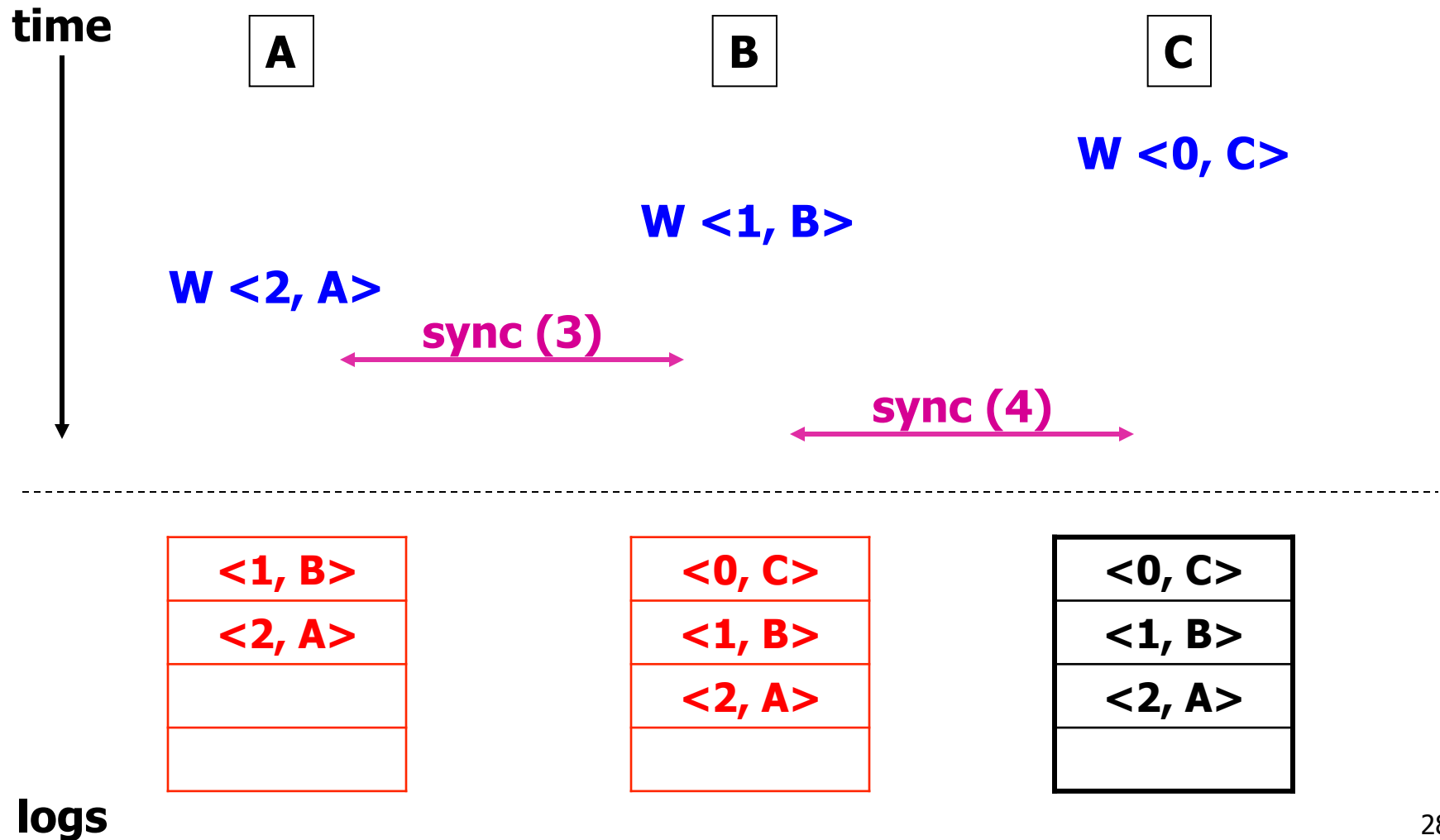

Trimming the Log

- When nodes receive new CSNs, can discard all committed log entries seen up to that point
 - Update protocol guarantees CSNs received in order
- Instead, keep copy of whole database as of highest CSN
 - By definition, official committed database
 - Everyone does (or will) agree on contents
 - Entries never need go through conflict resolution

Trimming the Log

- When nodes receive new CSNs, can discard all committed log entries seen up to that point

Result: no need to keep years of log data!

- Instead, keep copy of whole database as of highest CSN
 - By definition, official committed database
 - Everyone does (or will) agree on contents
 - Entries never need go through conflict resolution

Ordering of Commits by Primary Replica

- **Can primary commit writes in any order it pleases?**
 - Suppose user creates appointment, then decides to delete it, or change attendee list
 - **What order must these ops take in CSN order?**
 - Create first, then delete or modify
 - Must be true in every node's view of tentative log entries, too!
- **Total order of writes must preserve order of writes made at each node**
 - Not necessarily order among different nodes' writes

How Does Primary Replica Commit Each Node's Writes in Order?

- Nodes don't quite use real-time clocks for timestamps—use **Lamport logical clocks**
 - Anytime see message with later timestamp than current time, set clock to after that timestamp
- All nodes send updates **in order**
- So primary receives updates in per-node causal order, and commits them in that order

Syncing with Trimmed Logs

- Suppose nodes discard all writes in log with CSNs
 - Just keep copy of “stable” DB, reflecting discarded entries
- Cannot receive writes that conflict with DB
 - Only could be if write has CSN less than a discarded CSN
 - Already saw all writes with lower CSNs in right order—if see them again, can discard!

Syncing with Trimmed Logs (2)

- To propagate to node X
- If node X's highest CSN less than mine:
 - Send X full stable DB
 - X uses that DB as starting point
 - X can discard all his CSN log entries
 - X can play his tentative writes into that DB
- If node X's highest CSN greater than mine:
 - X can ignore my DB!

Bayou: Summary

- Seems more useful than Palm's calendar!
 - Often disconnected when making appointments
 - Automatic conflict resolution convenient
- Not at all transparent to applications!
 - Very strange programming practices
 - Writes are code, not just bits!
 - Check for conflicts, resolve conflicts
- Doesn't work for all apps
 - Bank account may be OK
 - But hard to imagine for source code repository!