

Network File System (NFS)

Brad Karp
UCL Computer Science



CS 0133
7th October 2019

NFS Is Relevant

- Original paper from 1985
- Very successful, still widely used today
- Early result; much subsequent research in networked filesystems “fixing shortcomings of NFS”
- NFS is a great substrate for cool distributed systems research projects!

Why Build NFS?

- Why not just store your files on local disk?
- Sharing data: many users reading/writing **same files** (e.g., code repository), but running on **separate machines**
- Manageability: ease of backing up **one server**
- Disks may be expensive (true when NFS built; **no longer true**)
- Displays may be expensive (true when NFS built; **no longer true**)

Goals for NFS

- Work with existing, unmodified apps:
 - Same semantics as local UNIX filesystem
- Easily deployed
 - Easy to add to existing UNIX systems
- Compatible with non-UNIX OSes
 - Wire protocol cannot be too UNIX-specific
- Efficient “enough”
 - Needn’t offer same performance as local UNIX filesystem

Goals for NFS

- Work with existing, unmodified apps:
 - Same semantics as local UNIX filesystem
- Easily deployed
 - Easy to add to existing UNIX systems
- Compatible with non-UNIX OSes
 - Wire protocol cannot be too UNIX-specific

Ambitious, conflicting goals!

Does NFS achieve them all fully?

Hint: Recall “New Jersey” approach

NFS Architecture

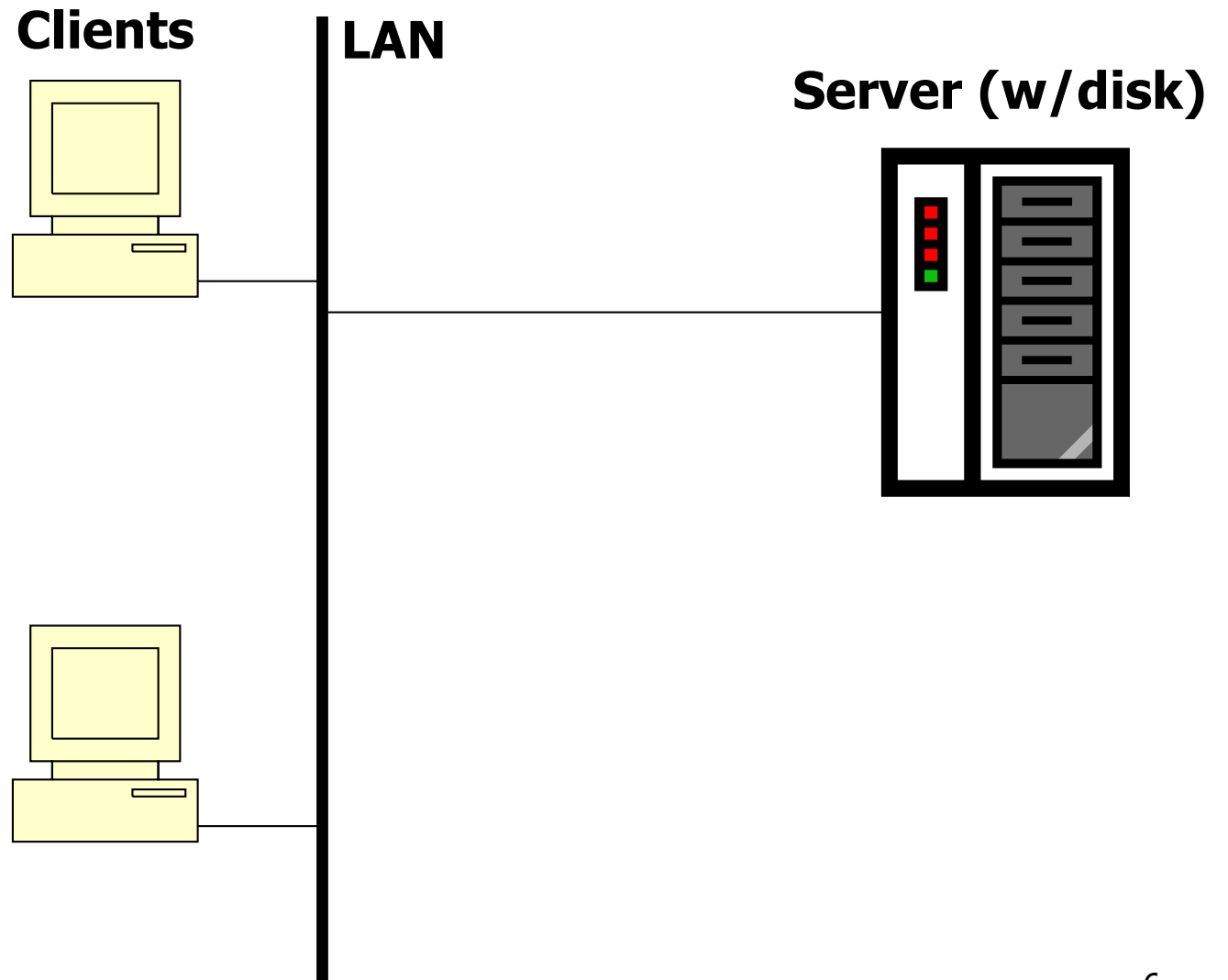

NFS Architecture

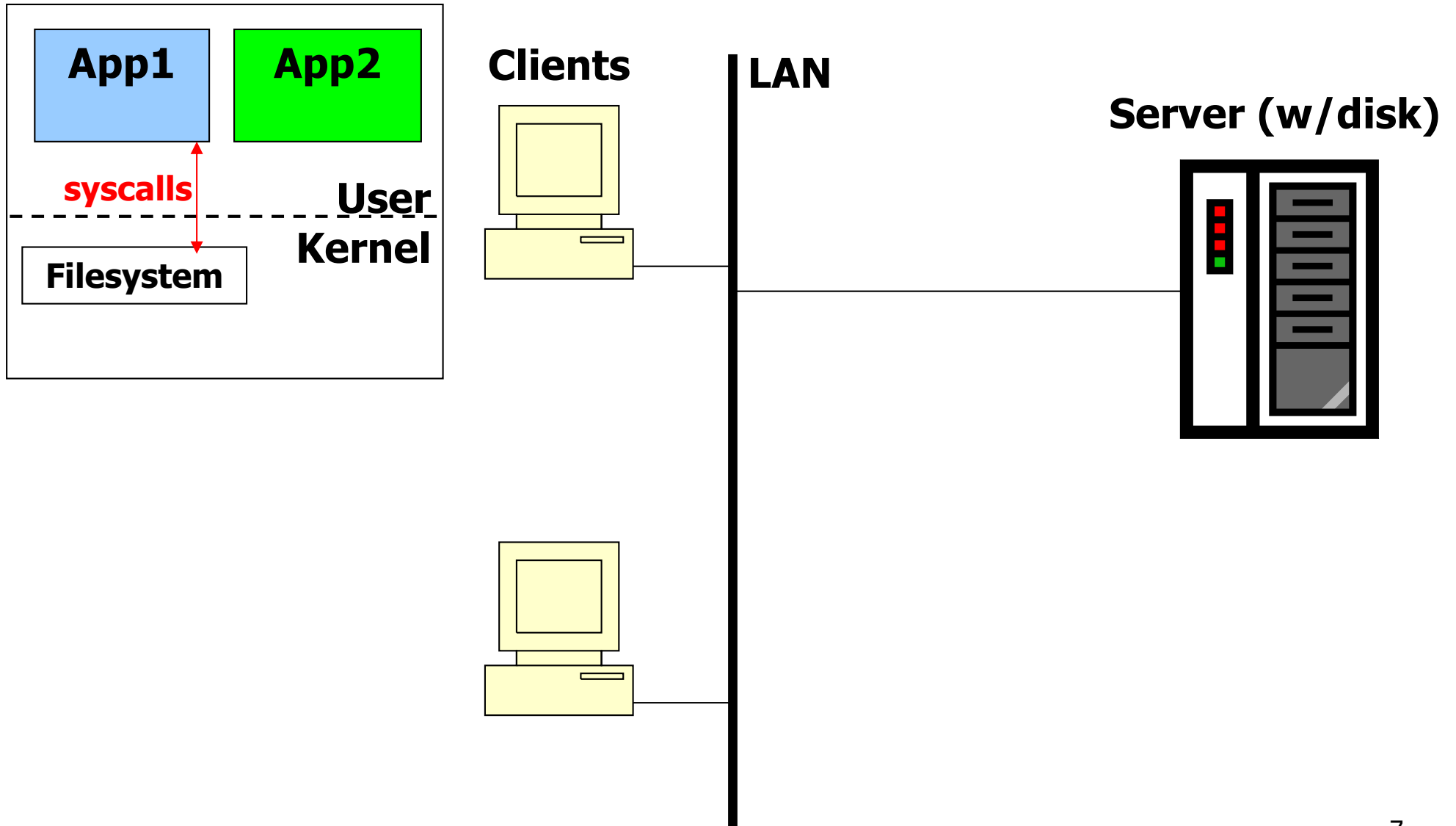

NFS Architecture

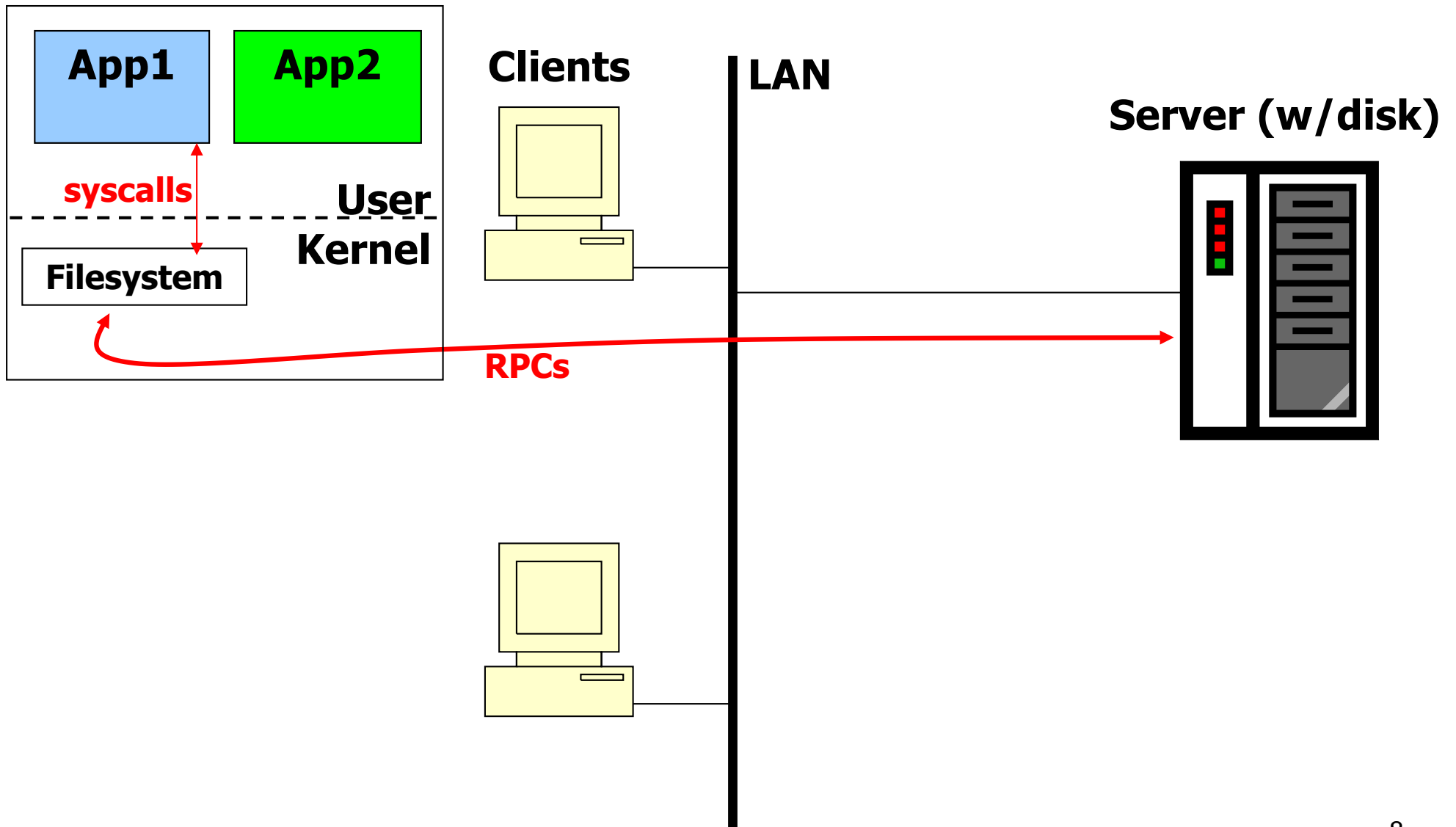

Simple Example: Reading a File

- What RPCs would we expect for:

```
fd = open("f", 0);  
read(fd, buf, 8192);  
close(fd);
```

Simple Example: NFS RPCs for Reading a File

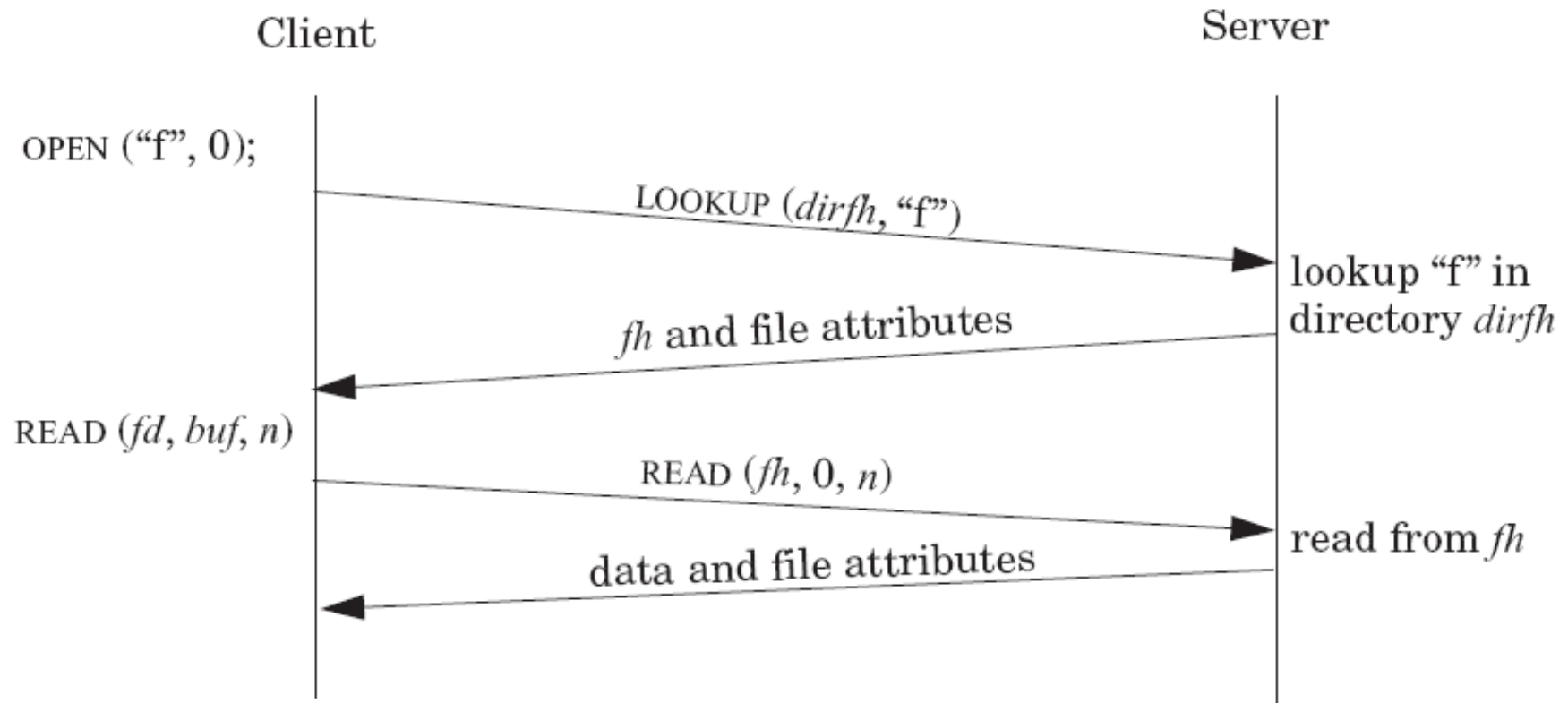

- Where are RPCs for `close()`?

File Handle: Function and Contents

- 32-byte name, opaque to client
- Identifies object on remote server
- Must be included in all NFS RPCs
- File handle contains:
 - filesystem ID
 - i-number (essentially, physical block ID on disk)
 - generation number

Generation Number: Motivation

- Client 1 opens file
- Client 2 opens same file
- Client 1 deletes the file, creates new one
- UNIX local filesystem semantics:
 - Client 2 (App 2) sees old file
- In NFS, suppose server re-uses i-node
 - Same i-number for new file as old
 - RPCs from client 2 refer to new file's i-number
 - Client 2 sees new file!

Generation Number: Solution

- Each time server frees i-node, increments its generation number
 - Client 2's RPCs now use old file handle
 - Server can distinguish requests for old vs. new file
- Semantics still not same as local UNIX fs!
 - Apps 1 and 2 sharing local fs: client 2 will see old file
 - Clients 1 and 2 on different workstations sharing NFS fs: client 2 gets error "stale file handle"

Generation Number: Solution

- Each time server frees i-node, increments its generation number

Trade precise UNIX fs semantics for simplicity

New Jersey approach...

- Semantics still not same as local UNIX fs!
 - Apps 1 and 2 sharing local fs: client 2 will see old file
 - Clients 1 and 2 on different workstations sharing NFS fs: client 2 gets error "stale file handle"

Why i-numbers, not Filenames?

Program 1 on client 1

```
CHDIR ("dir1");  
fd = OPEN ("f", READONLY);
```

```
READ (fd, buf, n);
```

Program 2 on client 2

```
RENAME ("dir1", "dir2");  
RENAME ("dir3", "dir1");
```

Time



- Local UNIX fs: client 1 reads dir2/f
- NFS with pathnames: client 1 reads dir1/f
- Concurrent access by clients can change object referred to by filename
 - Why not a problem in local UNIX fs?
- i-number refers to actual object, not filename

Where Does Client Learn File Handles?

- Before READ, client obtains file handle using LOOKUP or CREATE
- Client stores returned file handle in vnode
- Client's file descriptor refers to vnode
- **Where does client get very first file handle?**

NFS Implementation Layering

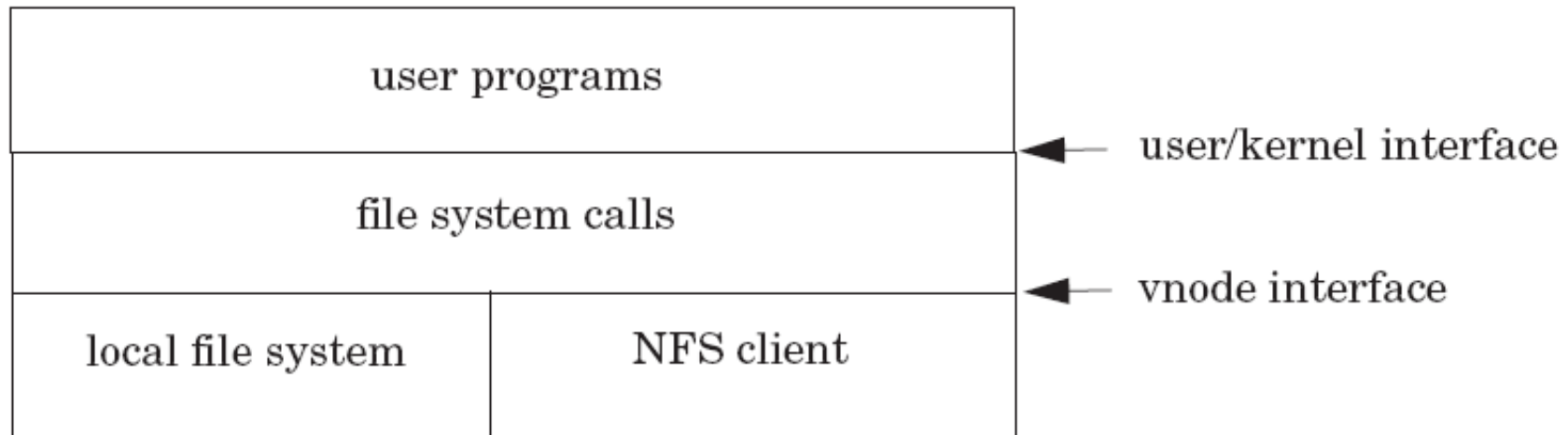

- Why not just send syscalls over wire?
- UNIX semantics defined in terms of files, not just filenames: file's identity is i-number on disk
- Even after rename, all these refer to same object as before:
 - File descriptor
 - Home directory
 - Cache contents

NFS Implementation Layering

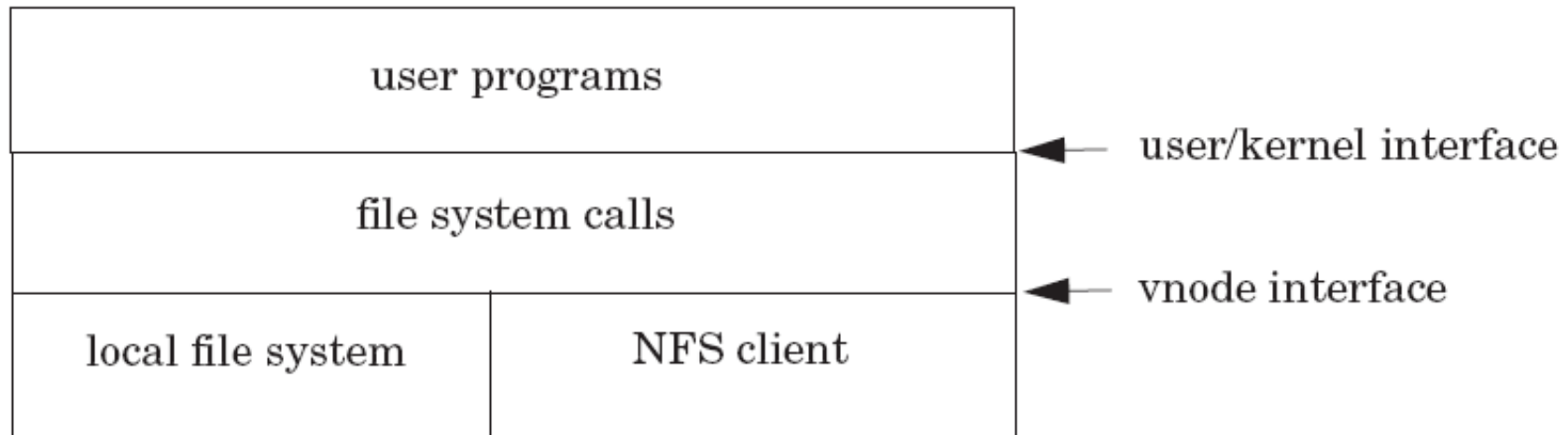

vnode's purpose: remember file handles!

filenames: file's identity is i-number on disk

- Even after rename, all these refer to same object as before:
 - File descriptor
 - Home directory
 - Cache contents

Example: Creating a File over NFS

- Suppose client does:

```
fd = creat("d/f", 0666);  
write(fd, "foo", 3);  
close(fd);
```
- RPCs sent by client:
 - newfh = LOOKUP (fh, "d")
 - filefh = CREATE (newfh, "f", 0666)
 - WRITE (filefh, 0, 3, "foo")

Server Crashes and Robustness

- Suppose server crashes and reboots
- Will client requests still work?
 - Will client's file handles still make sense?
 - Yes! File handle is disk address of i-node
- What if server crashes just after client sends an RPC?
 - Before server replies: client doesn't get reply, retries
- What if server crashes just after replying to WRITE RPC?

WRITE RPCs and Crash Robustness

- What must server do to ensure correct behavior when crash after WRITE from client?
- Client's data safe on disk
- i-node with new block number and new length safe on disk
- Indirect block safe on disk
- Three writes, three seeks: 30 ms
- 33 WRITES/s, 8 KB/WRITE, so **267 KB/s**

WRITEs and Throughput

- Design for higher write throughput:
 - Client writes entire file sequentially at Ethernet speed (few MB/s)
 - Update inode, &c. afterwards
- Why doesn't NFS use this approach?
 - What happens if server crashes and reboots?
 - Does client believe write completed?
- Improved in NFSv3: WRITEs async, COMMIT on close()

Client Caches in NFS

- Server caches disk blocks
- Client caches file content blocks, some clean, some dirty
- Client caches file attributes
- Client caches name-to-file-handle mappings
- Client caches directory contents
- General concern: **what if client A caches data, but client B changes it?**

Multi-Client Consistency

- Real-world examples of data cached on one host, changed on another:
 - Save in emacs on one host, “make” on other host
 - “make” on one host, run program on other host
- (No problem if users all run on one workstation, or don't share files)

Consistency Protocol: First Try

- On every read(), client asks server whether file has changed
 - if not, use cached data for file
 - if so, issue READ RPCs to get fresh data from server
- Is this protocol sufficient to make each read() see latest write()?
- What's effect on performance?
- Do we need such strong consistency?

Compromise: Close-to-Open Consistency

- Implemented by most NFS clients
- Contract:
 - if client A write()s a file, then close()s it,
 - then client B open()s the file, and read()s it,
 - client B's reads will reflect client A's writes
- Benefit: clients need only contact server during open() and close()—not on every read() and write()

Compromise: Close-to-Open Consistency

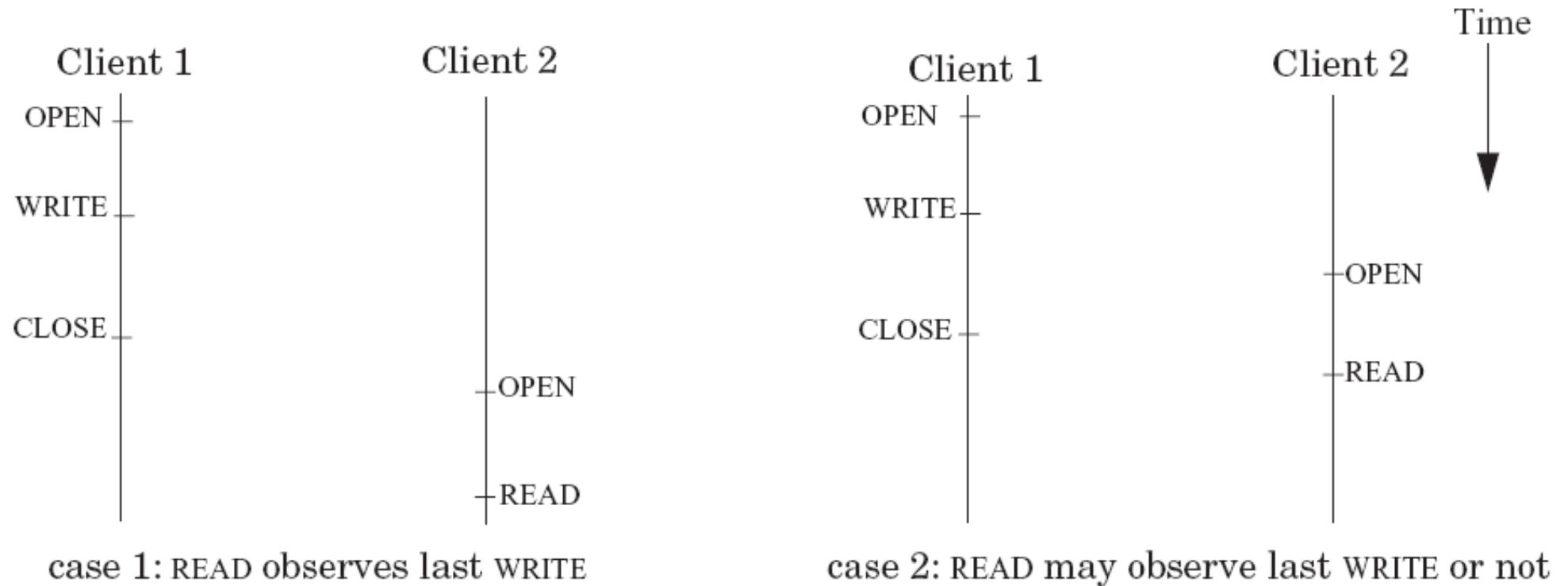

Compromise: Close-to-Open Consistency

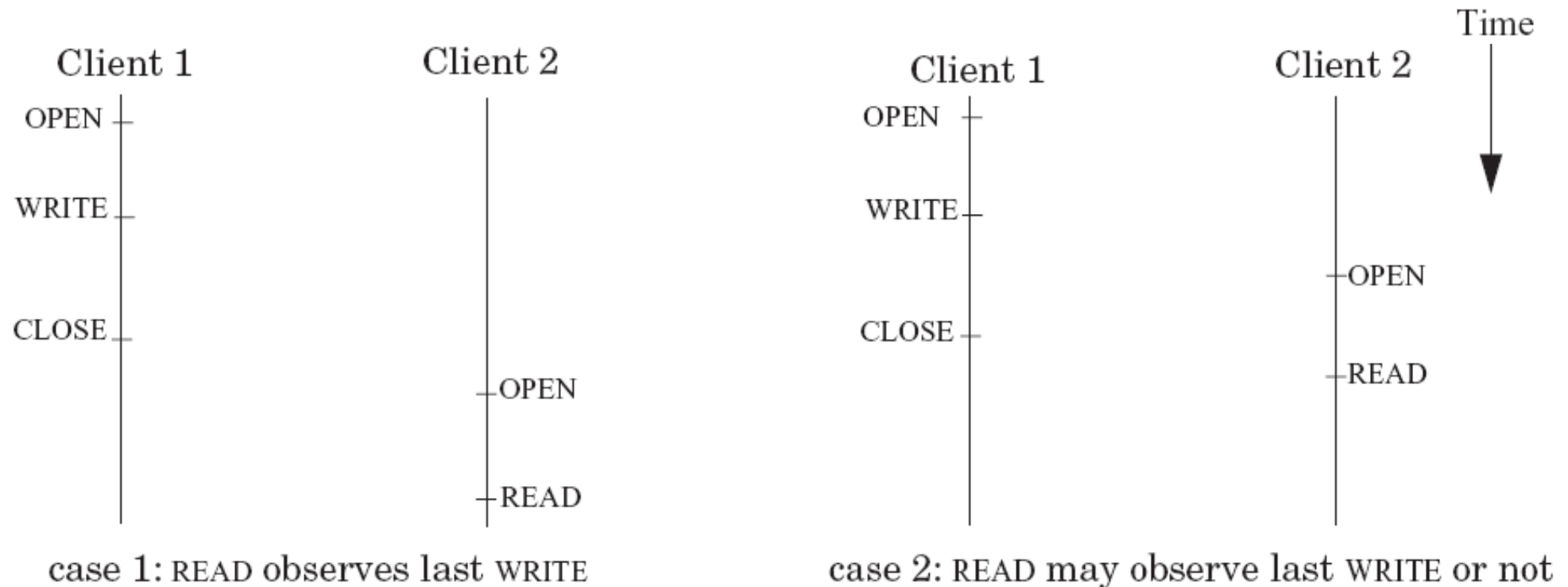

**Fixes "emacs save, then make" example...
...so long as user waits until emacs says it's
done saving file!**

Close-to-Open Implementation

- FreeBSD UNIX client (not part of protocol spec):
 - Client keeps file mtime and size for each cached file block
 - close() starts WRITES for all file's dirty blocks
 - close() waits for all of server's replies to those WRITES
 - open() always sends GETATTR to check file's mtime and size, caches file attributes
 - read() uses cached blocks only if mtime/length have not changed
 - client checks cached directory contents with GETATTR and ctime

Name Caching in Practice

- Name-to-file-handle cache not always checked for consistency on each LOOKUP
 - If file deleted, may get “stale file handle” error from server
 - If file renamed and new file created with same name, may even get wrong file’s contents

NFS: Secure?

- What prevents unauthorized users from issuing RPCs to an NFS server?
 - e.g., **remove files, overwrite data, &c.**
- What prevents unauthorized users from forging NFS replies to an NFS client?
 - e.g., **return data other than on real server**

NFS: Secure?

- What prevents unauthorized users from issuing RPCs to an NFS server?
 - e.g., **remove files, overwrite data, &c.**
- What prevents unauthorized users from forging NFS replies to an NFS client?
 - e.g., **return data other than on real server**

IP-address-based authentication of mount requests weak at best; no auth of server to client

Security not a first-order goal in original NFS

Limitations of NFS

- **Security:** what if untrusted users can be root on client machines?
- **Scalability:** how many clients can share one server?
 - Writes always go through to server
 - Some writes are to “private,” unshared files that are deleted soon after creation
- Can you run NFS on a **large, complex network?**
 - Effects of latency? Packet loss? Bottlenecks?

Limitations of NFS

- **Security:** what if untrusted users can be root on client machines?

**Despite its limitations, NFS a huge success:
Simple enough to build for many OSes
Correct enough and performs well enough to
be practically useful in deployment**

that are deleted soon after creation

- Can you run NFS on a **large, complex network?**
 - Effects of latency? Packet loss? Bottlenecks?